



Axis Camera with VaxALPR On Camera Software Camera Field Installation

Version 2.0

June 2019

VAXTOR UK (HQ)
8 Martinfield
Welwyn Garden City
Hertfordshire. AL7 1HG / UK
Tel: +44 (0)1707 808650
Info.uk@vaxtor.com

VAXTOR SPAIN
Ronda de Poniente 15. 28760
Tres Cantos (Spain)
Tel: +34 91 757 22 11
info.eu@vaxtor.com

VAXTOR USA
23201 Lake Center Drive, Suite 211
Lake Forest, CA 92630 (USA)
Toll Free: 877-5-VAXTOR
Outside US: +1-949-444-5829
info.us@vaxtor.com

VAXTOR SINGAPORE
18 Howard Road #07-01/1 1
369585, Singapore
Phone: +65 8613 3554
Info.asia@vaxtor.com

INDEX

Introduction	3
Camera Location for License Plate Recognition	3
1.1 Minimizing false triggering during recognition	3
1.2 Camera Installation	3
1.2.1 Gate or Barrier Installation.....	4
1.2.2 Roadside Installation	5
a. Gantry Mounted for front or rear capture (Front is normally recommended)	5
b. Pole Mounted to the side of the road.....	6

Introduction

This guide has been designed for those responsible for installing the VaxALPR software onto a suitable Axis camera.

The VaxALPR On Camera software is a real-time solution for Automatic License Plate Recognition (ALPR) that runs entirely within the Axis camera. Plate reads are stored within the camera and can be transmitted to a variety of remote back offices using the many transmission protocols supported by the on-board software.

For a full description of the software's features and capabilities, contact Vaxtor.

Camera Location for License Plate Recognition

This is the single most important factor in achieving high recognition accuracy. The installer should optimize the license plate character height (in pixels) and the perspective and angle of the license plate within the camera's image.

The location of the camera has a crucial role in the overall performance of the ALPR system and must be treated with the utmost care.

1.1 Minimizing false triggering during recognition

It is important to install the camera in a way that no high contrast objects (e.g. billboards, wire fences, trees, windows in buildings, parked vehicles etc.) are visible in the image frame.

These objects may cause false triggering during recognition. Additionally, the camera should not be pointed directly at light sources such as the sun, bright streetlights or reflective surfaces such as road-signs.

1.2 Camera Installation

In this section, we will describe the optimal settings for high accuracy ALPR.

You should consider the camera's distance from the target plate, camera height, image field of view and depth of field which affects focus.

The following recommendations will help you fully understand the effects of camera placement.

1.2.1 Gate or Barrier Installation

In this scenario, the vehicle approaches a barrier and comes to a complete stop before entering or leaving a controlled area. When installing the ALPR camera, we recommend the following:

- The **Distance** between the camera & the reading point should be **between 2 & 6 meters**.
- The **Height of the camera** should be **above or below the level of the barrier** so that it does not block camera's vision. If it is above the barrier, it should ideally be between 1.5 and 2 meters high.
- The **Camera's vertical angle** to the plate should be **less than 30 degrees**. (see below)
- The **Camera's horizontal angle** to the plate should be **less than 20 degrees**. (see below)
- When the camera is setup to read plates in a **single lane**:
 - The full width of the vehicle should fill the field on view, - no more.
- When the camera is setup to read plates across **multiple lanes**:
 - One camera should cover a maximum of 2 lanes.
 - The captured image should only be filled with the full width of the two vehicles.
- The **Aperture** of the lens should normally be between f/5.6 and f/8 to produce an adequate depth of field. The smaller the lens aperture, the more "in-focus" objects will be at varying distances.
- The **Camera** should have an **IR illuminator**. This should preferably be internal as the LEDs will be closer to the lens meaning that more light is reflected back from the plate at close distances. (This LED to lens angle should be less than 5°).

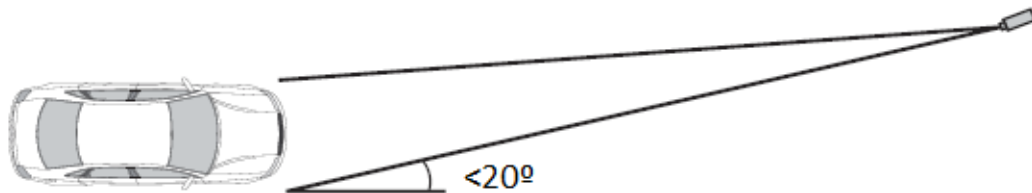

Maximum recommended angle on the horizontal axis

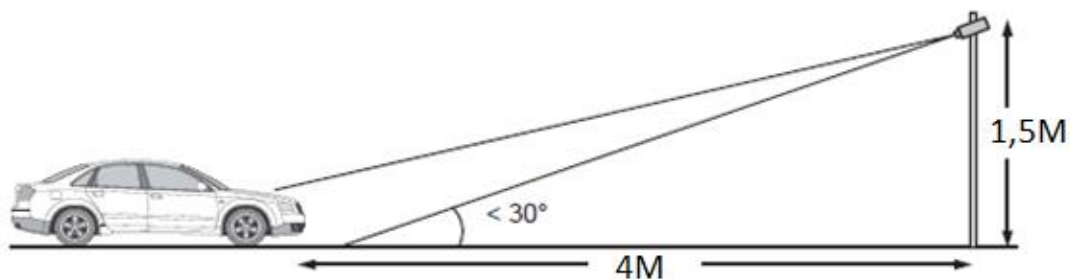

Maximum recommended angle on the vertical axis

1.2.2 Roadside Installation

In this scenario, the vehicle is in motion and the ALPR camera can be sited on an overhead gantry looking down on the traffic or mounted on a pole to the side of the road.

a. Gantry Mounted for front or rear capture (Front is normally recommended)

When installing the ALPR camera on an overhead gantry or bridge, we recommend the following settings:

- The **Distance** from the camera and the reading point should be **between 15 and 30 meters**.
- The **Camera height** should be **between 3.5 and 6 meters**.
NOTE: The height limit of the vehicles should be considered.
- The **Camera's vertical angle** to the plate should be **within 30 degrees**.
- When the camera is setup to read plates in a **single lane**:
 - The camera should be centered in the lane. (See below)
 - The full width of the vehicle should fill the field on view, - no more.
- When the camera is setup to read plates across **multiple lanes**:
 - One camera should cover a maximum of 2 lanes. (See below)
 - The camera should be centered across the two lanes.
 - The captured image should only be filled with the full width of the two vehicles.
- The **Aperture** of the lens should be set to between f/5.6 and f/8 to produce an adequate depth of field. The smaller the lens aperture, the more "in-focus" objects will be at varying distances.
- The **Camera** should be fitted with a powerful **IR illuminator** that can evenly diffuse the light across the whole of the field of view.

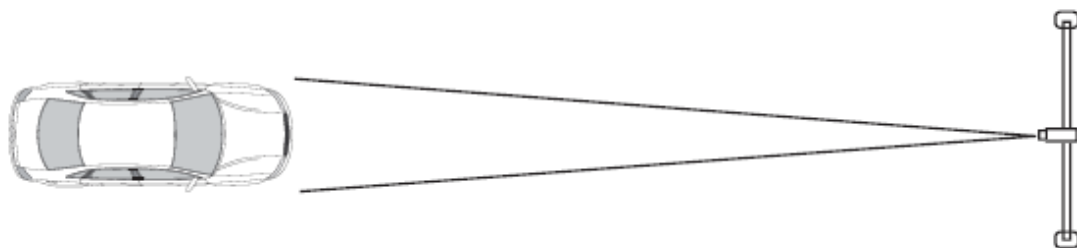

Camera with a front view of a single lane from a gantry

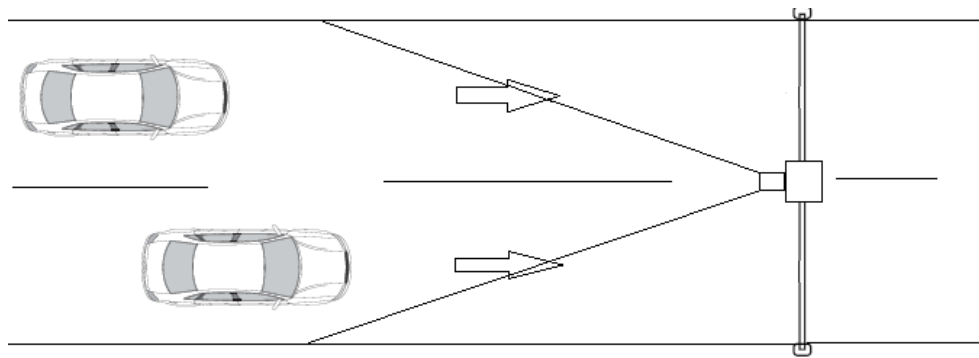

Camera with a front view of two adjacent lanes from a gantry

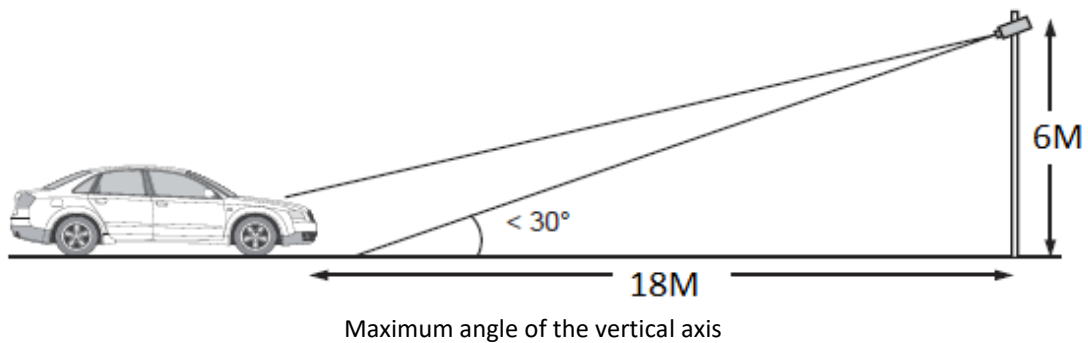

Maximum angle of the vertical axis

b. Pole Mounted to the side of the road

When installing the ALPR camera on the side of the road, we recommend the following settings:

- The **Pole** should be as **close to the road** as possible to minimize angles and to avoid capturing unnecessary objects. Use an out-rigger if necessary to reduce the angles.
- The **Distance** from the camera and the reading point should be **between 15 and 30 meters**.
- The **Height of the camera** should be **between 3.5 and 6 meters** to capture the front part of the vehicle only.
- The **Camera's vertical angle** to the plate should be **within 30 degrees**.
- The **Camera's horizontal angle** to the plate should be **within 20 degrees**.
- When the camera is setup to capture plates in a **single lane**:
 - The full width of the vehicle should fill the field on view, - no more. (See below)
- When the camera is setup to read plates across **multiple lanes**:
 - One camera should cover a maximum of 2 lanes. (See below)
 - The captured image should only be filled with the full width of the two vehicles.
- The **Aperture** of the lens should normally be between f/5.6 and f/8 to produce an adequate depth of field. The smaller the lens aperture, the more "in-focus" objects will be at varying distances.
- The Camera should be fitted with a powerful **IR illuminator** that can evenly diffuse the light across the whole of the field of view.

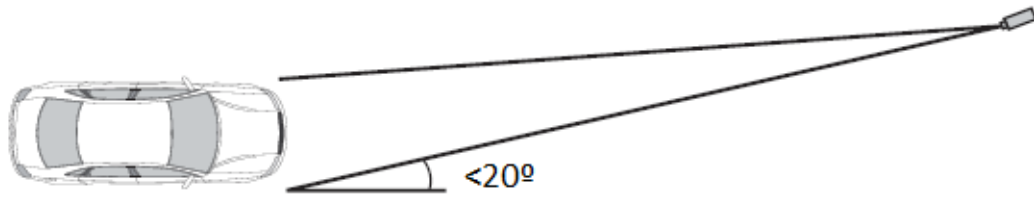

Camera's recommended horizontal setup angle

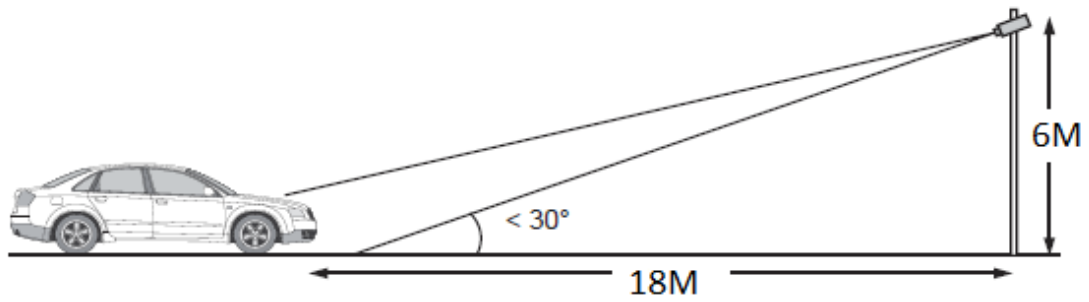

Camera's recommended vertical setup angle